

WE CREATE YOUR TOMORROW!



New

Machining Al wheels

Optimum edge treatment and advanced clamping technology

Feature

- Optimum configurations for aluminum wheel operation
- Excellent tool-life by employ new grade
- Strong clamping of insert by unique clamping mechanism
- Various insert type for wide coverage

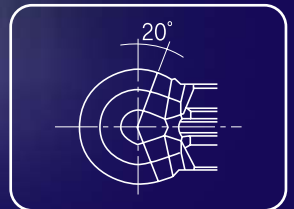

* Complete radius through out the cutting edge

Various insert style



MRGN-A
(General use)

- High rake angle
- Cutting conditions
V = 1,000 ~ 2,500 m/min
3,300 ~ 8,300 sfm
f = 0.1 ~ 0.8 mm/rev
0.004 ~ 0.031 ipr
d = 0.5 ~ 4.0 mm
0.02 ~ 0.16 inch



MRGN-A5
(Copy machining)

- Reinforced clamping
- Cutting conditions
V = 1,000 ~ 2,500 m/min
3,300 ~ 8,300 sfm
f = 0.1 ~ 0.8 mm/rev
0.004 ~ 0.031 ipr
d = 0.5 ~ 4.0 mm
0.02 ~ 0.16 inch



MRGN-AM
(Medium finishing)

- Medium-finishing cut
- For ductile cast iron
- Cutting conditions
V = 1,000 ~ 2,500 m/min
3,300 ~ 8,300 sfm
f = 0.1 ~ 0.6 mm/rev
0.004 ~ 0.024 ipr
d = 0.5 ~ 3.0 mm
0.02 ~ 0.12 inch



MRGN-AP
(PCD insert)

- Improved chip control
- Cutting conditions
V = 1,000 ~ 3,000 m/min
3,300 ~ 9,900 sfm
f = 0.1 ~ 0.6 mm/rev
0.004 ~ 0.024 ipr
d = 0.5 ~ 2.0 mm
0.02 ~ 0.08 inch

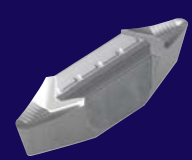

MVGN-A
(For fine finishing)

- High rake, high relief angle
- Cutting conditions
V = 1,000 ~ 2,500 m/min
3,300 ~ 8,300 sfm
f = 0.1 ~ 0.8 mm/rev
0.004 ~ 0.031 ipr
d = 0.5 ~ 4.0 mm
0.02 ~ 0.08 inch

Machining Al wheels

New



New clamping System

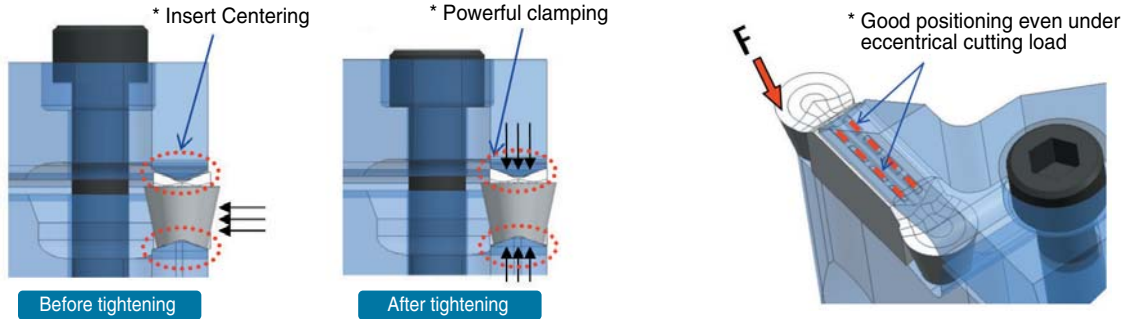

- "Radius" designed on top & bottom side of insert reinforce the clamping force.
- Convex "DOT" put on insert top part makes it possible to have powerful & even clamping.

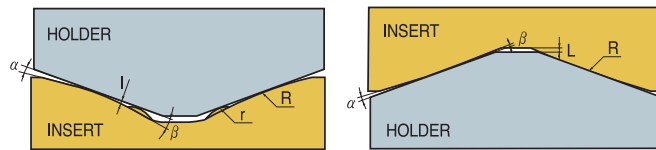

Application of Al wheel

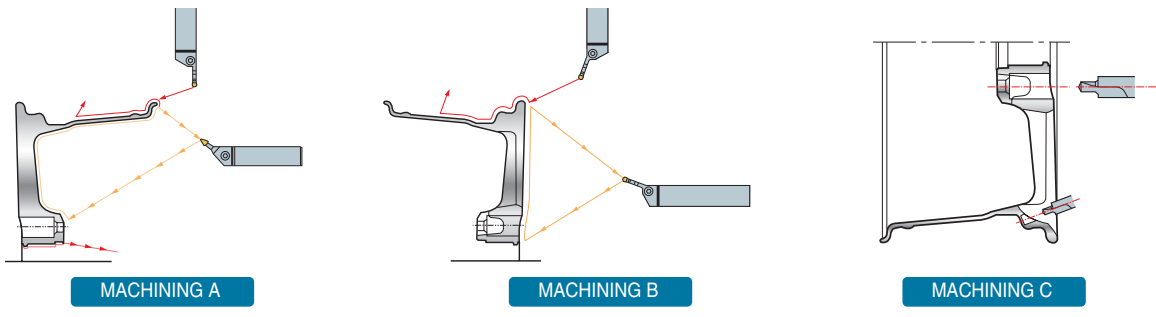

INSERT



Configuration	Grade			Specifications(mm)					FIG	Available holder
	G10	H05	H01	W	R	L	t	h		
MRGN6N-A	●			6.0	3.0	26.0	7.2	5.9	1	MGEHR/L25N-6A
MRGN6N-AM	●			6.0	3.0	26.0	7.2	5.9	1	
MRGN6N-AP	●			6.0	3.0	26.0	7.2	5.9	1	
MRGN6N-A5	●			6.0	3.0	26.0	7.2	5.9	1	
MRGN8N-A	●			8.0	4.0	30.0	8.0	6.5	1	MGEHR/L32N-8A
MRGN8N-AM	●			8.0	4.0	30.0	8.0	6.5	1	
MRGN8N-AP	●			8.0	4.0	30.0	8.0	6.5	1	
MRGN8N-A5	●			8.0	4.0	30.0	8.0	6.5	1	
MVGN8N-A-R1.2	●			8.0	1.2	30.0	8.0	6.9	2	MGEXR/L25N-8A-22.5°
MVGN8N-A-R1.6	●			8.0	1.6	30.0	8.0	6.9	2	

Machining Al wheels

New

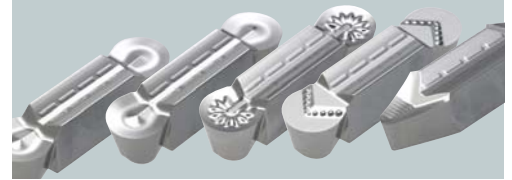

HOLDER

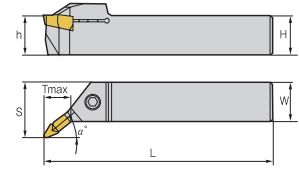
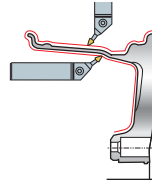

Designation	Stock		Dimension(mm)						Available Insert	Screw	Screw Driver
	R	L	H(h)	W	L	S	T max	α°			
MGEXR/L25N-8A-5V	●		25	25	150	29	23.5	5	MVGN8N-A-R1.2	BHA0616	HW50L
MGEXR/L25N-8A-22.5V	●		25	25	150	35	15	22.5	MVGN8N-A-R1.6		

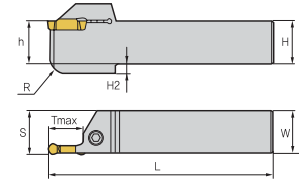
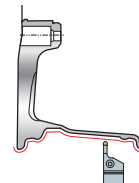

Designation	Stock		Dimension(mm)							Available Insert	Screw	Screw Driver
	R	L	H(h)	W	L	S	Tmax	R	H2			
MGEHR/L25N-6A	●		25	25	150	25.55	23.5	6	7	MRGN6N-A MRGN6N-AP MRGN6N-AM	BHA0616	HW50L
MGEHR/L32N-6A			32	32	150	32.55	27	12	8			
MGEHR/L25N-6A5	●		25	25	150	25.55	23.5	6	7			
MGEHR/L32N-6A5			32	32	150	32.55	27	12	8	MRGN6N-A5		
MGEHR/L25N-8A	●		25	25	150	25.55	23.5	6	7	MRGN8N-A MRGN8N-AP MRGN8N-AM		
MGEHR/L32N-8A	●		32	32	150	32.55	27	12	8			
MGEHR/L25N-8A5	●		25	25	150	25.55	23.5	6	7			
MGEHR/L32N-8A5	●		32	32	150	32.55	27	12	8	MRGN8N-A5		

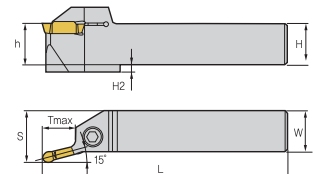
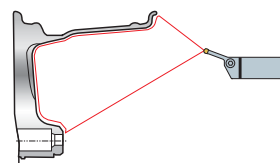

Designation	Stock		Dimension(mm)							Available Insert	Screw	Screw Driver
	R	L	H(h)	W	L	S	Tmax	R	H2			
MGEHR/L25N-6A-15	●		25	25	150	32.2	20	6	7	MRGN6N-A MRGN6N-AP MRGN6N-AM	BHA0616	HW50L
MGEHR/L32N-6A-15			32	32	150	39.2	25	12	8			
MGEHR/L25N-6A5-15	●		25	25	150	32.2	20	6	7			
MGEHR/L32N-6A5-15			32	32	150	39.2	25	12	8	MRGN6N-A5		
MGEHR/L25N-8A-15	●		25	25	150	32.2	20	6	7	MRGN8N-A MRGN8N-AP MRGN8N-AM		
MGEHR/L32N-8A-15	●		32	32	150	39.2	25	12	8			
MGEHR/L25N-8A5-15	●		25	25	150	32.2	20	6	7			
MGEHR/L32N-8A5-15	●		32	32	150	39.2	25	12	8	MRGN8N-A5		

BORING BAR

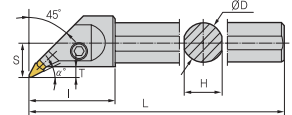
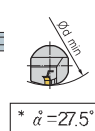
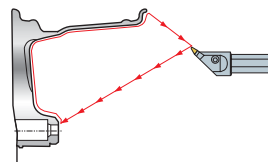

Designation	Stock		Dimension(mm)							Available Insert	Screw	Screw Driver
	R	L	$\varnothing D$	$\varnothing d_{min}$	L	I	T	H	S			
MGIUR/L6832-8A-MV	●		32	68	170	65	8.0	30	26	MVGN8N-A-R1.2 MVGN8N-A-R1.6	BHA0616	HW50L

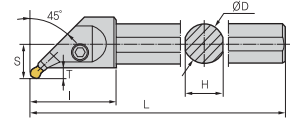
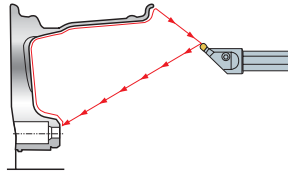

Designation	Stock		Dimension(mm)							Available Insert	Screw	Screw Driver
	R	L	ØD	Ødmin	L	I	T	H	S			
MGIUR/L6832-8A-MR	●		32	68	170	65	8.0	30	26	MRGN8N-A MRGN8N-AM MRGN8N-AP	BHA0616	HW50L
MGIUR/L6832-8A5-MR	●		32	68	170	65	8.0	30	26	MRGN8N-A5	BHA0616	HW50L

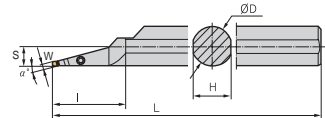
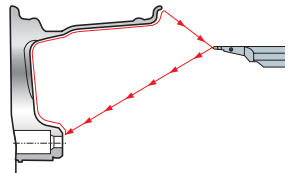

Designation	Stock		Dimension(mm)									Available Insert	Screw	Screw Driver
	R	L	ØD	Ødmin	L	I	W	H	α°	S				
MGIXR/L7050-8A-MR	●		50	70	350	80	8	46	27.5	30.2	MRGN8N-A MRGN8N-AM MRGN8N-AP	BHA0616	HW50L	
MGIXR/L7050-8A5-MR	●		50	70	350	80	8	46	27.5	30.2	MRGN8N-A5	BHA0616	HW50L	

Machining Example

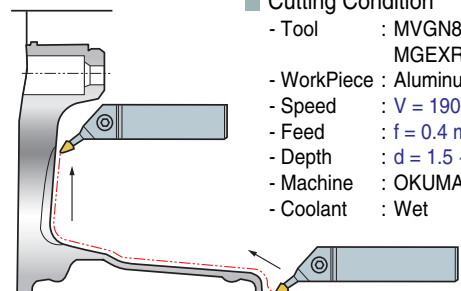

■ Cutting Condition

- Tool : MVGN8N-A-R1.2
MGEXR2525-8A-39.5V
- WorkPiece : Aluminum Alloys(15inch Wheel)
- Speed : $V = 1907 \text{ m/min}, 6255 \text{ sfm}$
- Feed : $f = 0.4 \text{ mm/rev}, 0.016 \text{ ipr}$
- Depth : $d = 1.5 \sim 2 \text{ mm}, 0.06 \sim 0.08 \text{ inch}$
- Machine : OKUMA
- Coolant : Wet

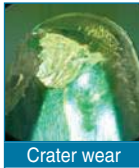

Crater wear

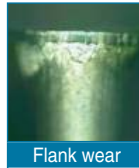

Flank wear



Built up edges



Machined parts (pcs)

Recommended cutting condition

Work piece		Hardness Brinell HB	Vc		f	
			m/min	sfm	mm/rev	ipr
Aluminum alloys (Forged)	Unhardenable	50~70	1,000 ~ 2,500	3,300 ~ 8,300	0.1 ~ 0.6	0.004 ~ 0.024
	Hardened	90~110	300 ~ 1,000	1,000 ~ 3,300	0.1 ~ 0.5	0.004 ~ 0.020
Aluminum alloys (Cast)	Unhardenable	70~80	300 ~ 1,000	1,000 ~ 3,300	0.1 ~ 0.5	0.004 ~ 0.020
	Hardened	80~110	200 ~ 600	650 ~ 2,000	0.1 ~ 0.4	0.004 ~ 0.016
Copper alloys	Short chipping	90~110	300 ~ 800	1,000 ~ 2,600	0.1 ~ 0.5	0.004 ~ 0.020
Magnesium alloys		70~80	300 ~ 1,000	1,000 ~ 3,300	0.1 ~ 0.5	0.004 ~ 0.020

Safety instruction

- Use safety glasses, face cover and other protection equipment.
- If cutting condition and use method are inaccurate, you may be injured by broken tools or scattering of chips.
- Excessive cutting load may have bad influence both tool and machine.
- Make suitable tool replacement cycle for preventing failure of machining.
- After machine stopped, clean remaining chip from machine by using special cleaning equipment.
- Keep safety distances from scattering of acute and hot chip during machining
- Make preparation to fire prevention countermeasures in advance if you use insoluble cutting oil.
- Assembled parts may be scattered at high speed cutting. Please use protection equipment.



HEAD OFFICE
1606-2, Seocho 1-Dong, Seocho-Gu, Seoul, Korea
TEL : +82 2 522 3181 FAX : +82 2 522 3184, +82 2 3474 4744
WEB : www.korloy.com

CHEONGJU FACTORY
53-16, Songjeong-Dong, Hunguk-Gu, Cheongju, Chungcheongbuk-Do, Korea
TEL : +82 43 262 0141 FAX : +82 43 262 0146
E-MAIL : ex part@korloy.com

JINCHON FACTORY
767-1, Guanghewon-1, Jirheon-Gun, Chungcheongbuk-Do, Korea
TEL : +82 43 535 0141 FAX : +82 43 535 0144